

FOLDING

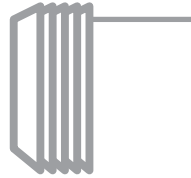

SLIDING



STACKING

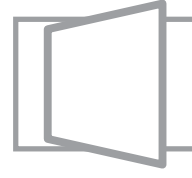

PIVOT

# PRODUCT OVERVIEW GUIDE

VISTA FOLD - C2, C3 & C5

## TABLE OF CONTENTS

CATEGORY	DETAILS	NOTES
Quote Width	Round to the nearest 16th	
Min. Panel Width	20"	<i>Refer to section A</i>
Max Panel Width	52"	<i>Refer to section A</i>
Quote Height	Round to the nearest 16th	
Min. Panel Height	18"	<i>Refer to section A</i>
Max Panel Height	C2/C3 - 144" (168" WZ3 or less) C5 - 168"	<i>Refer to section A</i>
Left Config	Type numerically	<i>Refer to section B</i>
Right Config	Type numerically	<i>Refer to section B</i>
Max Total Panel #	No Max - see product details	<i>Refer to section B</i>
Active (primary) Component	Left or Right	
Active Panel Override	Used to modify width of active panel. Type numerically, round to the 1/16". Odd configurations only.	This is by dealer request/project specific only.
Header/Jamb Color	Clear Anodized, White, Arcadia Silver, Bronze, Black, White, Wood Clad, Light Custom, Dark Custom	Faux wood options are custom colors.
Interior Panel Color	Clear Anodized, White, Arcadia Silver, Bronze, Black, White, Wood Clad, Light Custom, Dark Custom	Panel color matches header/jamb, unless the system has wood clad or is specified otherwise. Faux wood options are custom colors. <i>Refer to section C</i>
Exterior Panel Color	Clear Anodized, White, Arcadia Silver, Bronze, Black, White, Wood Clad (Special Request), Light Custom, Dark Custom	Panel color matches header/jamb, unless the system has wood clad or is specified otherwise. Faux wood options are custom colors. <i>Refer to section C</i>
Custom Color (when applicable)	Type alpha-numerically	Customer will need to provide specified powdercoat or kynar number used for the custom color they want for the project. A color swatch will need to be obtained and approved by the customer for the order to move into production.
Wood Clad Type (when applicable)	Douglas Fir, Mahogany/Sapele, White Oak, Ash, Birch, Curly Maple, Red Oak, Walnut, Zebrawood, Custom/Special	Faux wood options are custom colors. <i>Refer to section C</i>

CATEGORY	DETAILS	NOTES
Orientation	Inswing or Outswing	<i>Refer to section D</i>
Sill Color	Clear Anodized, White, Arcadia Silver, Bronze, Black, White, Wood Clad (Special Request), Light Custom, Dark Custom	<i>Refer to section C</i>
Sill Type	Standard, Modified/Riserless Standard, ADA, Channel	<i>Refer to section E</i>
Handle Type	Multipoint with key, Twinpoint, Keyed Twinpoint, Panic/Exit Device (pending approval)	<i>Refer to section F</i>
Hinge Color	Default, Clear Anodized, White, Bronze, Black	Leave default unless the customer specifically calls out a color preference.
Hinge Height Override	Engineering and CAD field	Leave this field set at 0. This is used exclusively by engineering or CAD on an as-needed basis.
Keyed TP System	Not Keyed, Keyed, Keyed Alike	This field is used for both twinpoints and panic devices. All panic devices are keyed?
Interior Twinpoint Color	Clear Anodized, White, Arcadia Silver, Bronze, Black, White, Wood Clad (Do not use), Light Custom, Dark Custom	<i>Refer to section C</i>
Exterior Twinpoint Color	Clear Anodized, White, Arcadia Silver, Bronze, Black, White, Wood Clad (Do not use), Light Custom, Dark Custom	<i>Refer to section C</i>
Primary TP Height Override	Engineering and CAD field numerical entry	Unless specified by the customer, leave this field set at 0. This is used almost exclusively by engineering or CAD on an as-needed basis.
Secondary TP Height Override	Engineering and CAD field numerical entry	Unless specified by the customer, leave this field set at 0. This is used almost exclusively by engineering or CAD on an as-needed basis.
Force Secondary Twinpoint	Engineering and CAD field	Leave this field set at "No". This is used exclusively by engineering or CAD on an as-needed basis.
Water Management	Yes or No	This is "No" by default and only provided on customer request. <i>Refer to section G</i>
Kickplate Quantity	None, Single Active, Both Active, All	This is "none" by default and only provided on customer request only. Both active can only be used on configurations with left and right sides. <i>Refer to section H</i>
Midrail Size	1", 2", 3", 4", 5", 6", 8", 10", 12"	This is "none" by default and only provided on customer request.
Glass Thickness	1" IG Impact 1" IG 9/16" Monolithic 1/2" Monolithic	3/8" Monolithic 1/4" Monolithic 1" Laminated*
		1" IG Impact and 9/16" Impact are the only 2 types approved for HVHZ and WZ3 use. *Do not use 1" Laminated.

CATEGORY	DETAILS	NOTES
Low E Coating	Low E 240 Solarban 60 Low E 270 Solarban 70 Low E 272 Solarban 70/72 Starphire Low E 340 Solarban 90 Low E 366 Viracon Options	Certain Low E options will tint the glass.
Tint	Clear Arctic Frost* Blue Bronze Gray Green Satin Etch Turtle Code Gray Starphire Low Iron	Certain tints are unavailable for certain coatings and sizes. This is dependent on the glass vendor, which could change depending on the Low E selected. *Arctic frost - laminate only
Argon & Cap. Tubes	None, Argon, Cap. Tubes, or Both	This is a customer requested option. Cap(illary) tubes are used for orders traveling to high altitude locations, and act as a 1-way valve to release internal pressures in IG units. Argon is an inert gas commonly used to achieve better heat/thermal transfer ratings.
Number of Lites Wide	Numerical entry, always at least 1	Default option is 1. A lite is the term used for a pane of glass. This option is also known as SDL - Simulated Divided Lites since the lite is still 1 piece of glass, but we apply an exterior piece to "divide" the lite into partitions. A lite with a single bar of extrusion running down the middle would be 2 lites wide. <i>Refer to section I</i>
Number of Lites High	Numerical entry, always at least 1	Default option is 1. A lite with a single bar of extrusion running across the middle would be a 2 lites high. <i>Refer to section I</i>
Internal Muntin (if Lites Wide/High is >0)	None, Anodized, White, Bronze, Black	Only IG glass can get internal muntin. This is the "shadow bar" that is found in between the glass layers. Black is used when a Solarban option of Low E is selected, and Bronze is used when an actual Low E is selected.
External Muntin (if Lites Wide/High is >0)	Yes or No	"Yes" is default unless the customer only wants internal muntin or if there are midrails/kickplates on the order.
External Muntin Width (if Lites Wide/High is >0)	None, 3/4", 7/8", 1", Custom 93", Custom 144"	This will be customer driven. Custom 93 and Custom 144 are in reference to non-standard muntin types. If a customer specifies a specific shape/type of muntin, please refer to the custom muntin sheet to determine if it comes in 93" or 144" stock lengths.
Muntin Type (if number of mull bars is >0)	Flat, Raised, OGEE	Flat, Raised, and OGEE are not available in every width. If any other door on the order gets Flat muntin, every unit on the order will get Flat muntin, unless the customer specifies otherwise. Multi slide and storefront systems exclusively use flat muntin. <i>Refer to section J</i>

CATEGORY	DETAILS	NOTES						
Number of Mull Bars (if number of mull bars is >0)	Numerical entry.	By customer request only. They will need to specify the number of mull bars needed.						
Mull Bar Size (if number of mull bars is >0)	<table border="0"> <tr> <td>1" x 3"</td> <td>2" x 6"</td> </tr> <tr> <td>1" x 4"</td> <td>2" x 8"</td> </tr> <tr> <td>1" x 6"</td> <td>2" x 10"</td> </tr> </table>	1" x 3"	2" x 6"	1" x 4"	2" x 8"	1" x 6"	2" x 10"	<p>This is customer driven and they will need to provide the mull size. WE DO NOT ADVISE ON MULL SIZE. This is a structural piece of material, and they will need to know if their mull bar size is appropriate for the application they're applying it to. <i>Refer to section K</i></p>
1" x 3"	2" x 6"							
1" x 4"	2" x 8"							
1" x 6"	2" x 10"							
Number of Mull Clips (if number of mull bars is >0)	Numerical entry. 2 per mull bar, unless otherwise specified.							

## A. MIN/MAX PANEL WIDTH/HEIGHT

Below are design pressure charts for impact rated folding.

### C3 - HVHZ

#### Panel Width (Inches)

Panel Height (Inches)	20	24	28	32	36	40	44	48	52	
	72	100	100	100	100	100	100	100	100	75
	76	100	100	100	100	100	100	100	100	75
	80	100	100	100	100	100	100	100	75	75
	84	100	100	100	100	100	100	100	75	65
	88	100	100	100	100	100	100	75	65	65
	92	100	100	100	100	100	100	75	65	65
	96	100	100	100	100	100	75	65	65	65
	100	100	100	100	100	94.3	75	65	65	
	104	100	100	100	92.9	75	75	65	+64.5/-65	
108	100	100	93.8	82.8	75	65	65			
112	100	97.3	83.9	75	75	65	+62.6/-65			
116	100	87.4	75.4	75	75	+64.5/-65				
120	94.2	78.9	75	75	+64.6/-65	+58.6/-63.5				
126	65	65	65	65	65	65				
132	65	65	65	65	65					
138	65	65	65	65	65					
144	65	65	65	65	65					

### C3 - WZ3

#### Panel Width (Inches)

Panel Height (Inches)	20	24	28	32	36	40	44	48	52	
	96	100	100	100	100	100	75	65	65	65
	102	100	100	100	98.7	88.6	75	65	65	
	108	100	100	93.8	82.8	75	65	65		
	114	100	92.2	79.5	75	75	65	+61.2/-65		
	120	94.2	78.9	75	75	+64.6/-65	+58.6/-63.5			
	126	81.3	75	74.4	65.5	+55.6/-60.2	+50.4/-54.6			
	132	75	75	64.6	+53.9/-58.4	+48.2/-52.2				
	138	75	65.6	56.5	+47.1/-51	+42.1/-45.6				
	144	69	57.7	49.6	+41.4/-44.8					
159	61	51	43.8	+36.5/-39.6						
156	54.2	45.3	+36.9/-40	+32.4/-35.1						
162	48.3	40.4	+32.9/-35.7							
168	43.3	36.2	+29.5/-32							

## B. CONFIGURATIONS / MAX NUMBER OF PANELS

---

**NOTE:**

PANELS SHOWN ARE BASED ON TESTING, OTHER APPROVED CONFIGURATIONS ARE AS FOLLOWS:

- 1 PANEL - 1L, 1R
- 2 PANEL - 2L, 2R, 1L 1R
- 3 PANEL - 3L, 3R, 2L 1R, 1L 2R
- 4 PANEL - 4L, 4R, 3L 1R, 1L 3R, 2L 2R
- 5 PANEL - 5L, 5R, 4L 1R, 1L 4R, 3L 2R, 2L 3R
- 6 PANEL - 6L, 6R, 5L 1R, 1L 5R 4L 2R, 2L 4R, 3L 3R
- 7 PANEL - 7L, 7R, 6L 1R, 1L 6R, 5L 2R, 2L 5R, 4L 3R, 3L 4R
- 8 PANEL - 8L, 8R, 7L 1R, 1L 7R, 6L 2R, 2L 6R, 5L 3R, 3L 5R, 4L 4R
- 9 PANEL - 9L, 9R, 8L 1R, 1L 8R, 7L 2R, 2L 7R, 6L 3R, 3L 6R, 5L 4R, 4L 5R

FOR DOOR WITH GLASS TYPE 1 & 2, OVERALL FRAME AREA SHALL NOT EXCEED 415 FT<sup>2</sup> (1.5 X TESTED FRAME AREA).

FOR DOOR WITH GLASS TYPE 3, 4, 5, 6, 7, 8, 9, & 10, OVERALL FRAME AREA SHALL NOT EXCEED 334 FT<sup>2</sup> (1.5 X TESTED FRAME AREA).

**Max Total Panel #    Unlimited**

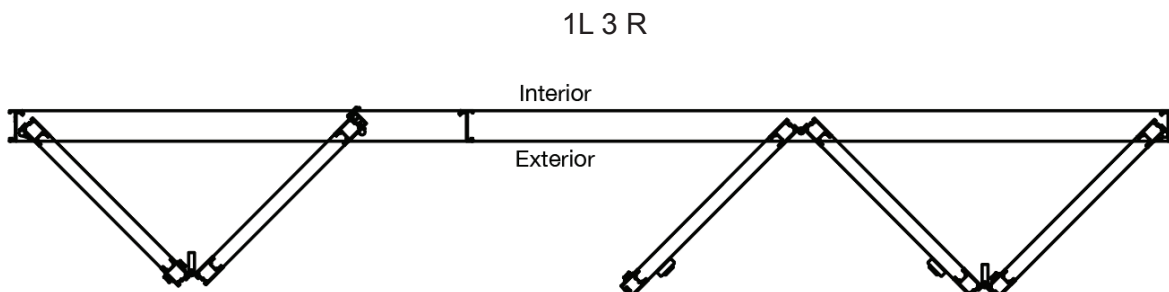

## C. FINISH OPTIONS

### Standard Finishes

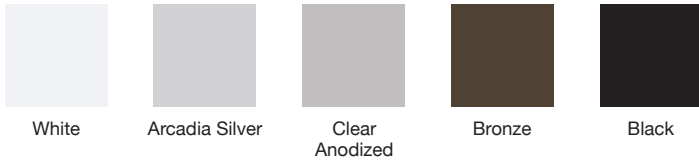

### Standard Wood Finishes



### Exotic Wood Finishes



### Faux Wood Grain Finishes

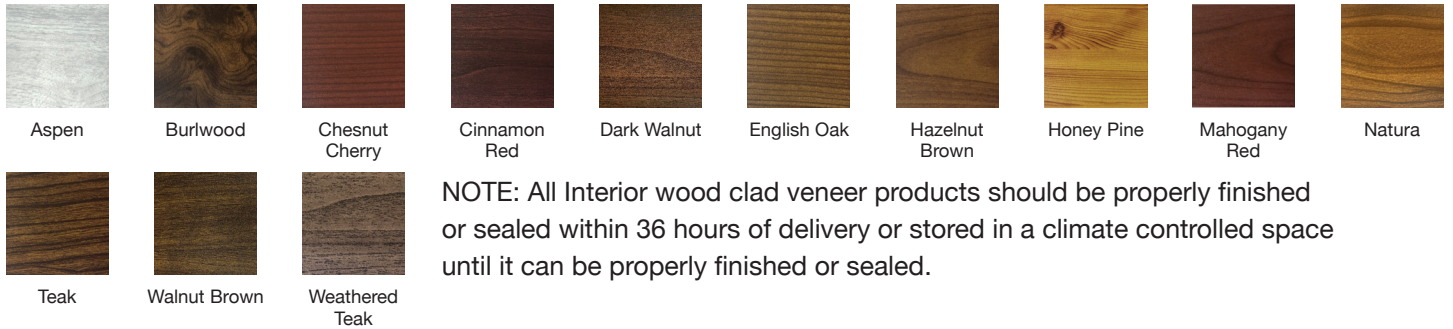

NOTE: All Interior wood clad veneer products should be properly finished or sealed within 36 hours of delivery or stored in a climate controlled space until it can be properly finished or sealed.

## D. ORIENTATION

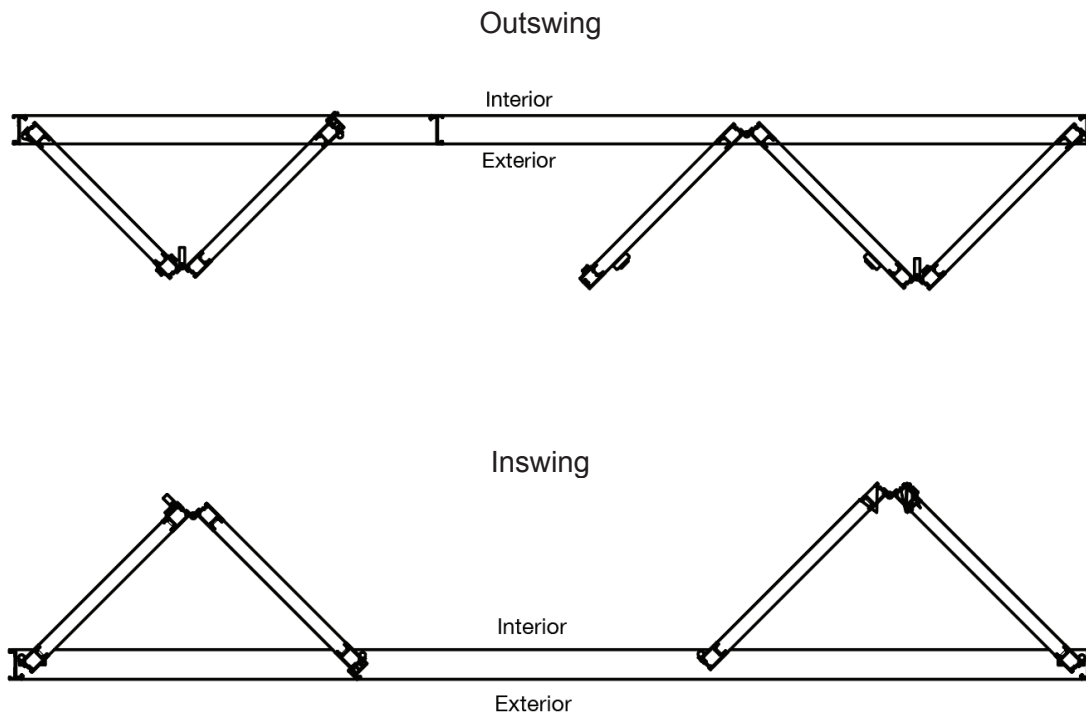



## E. SILL TYPE

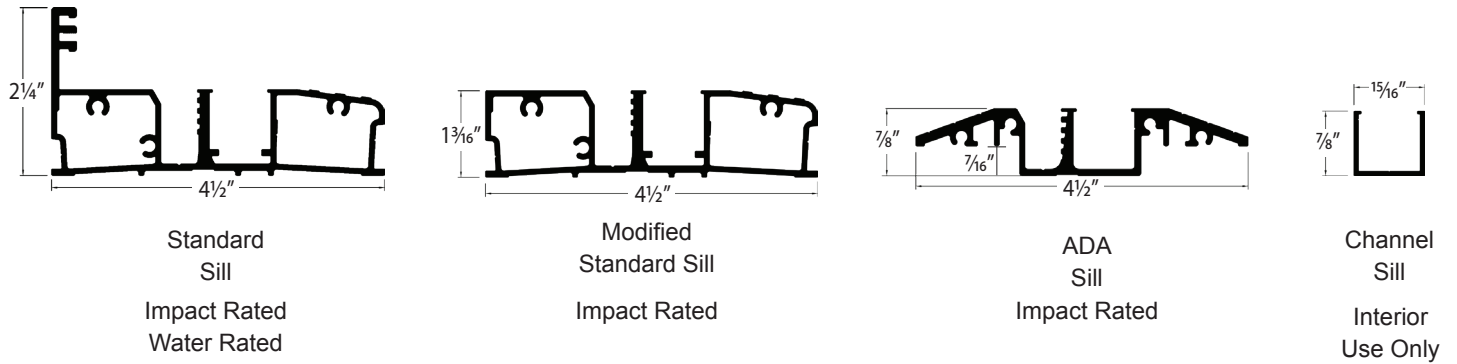

## F. HANDLE TYPE

Multi Point 5 Point Locking Handle

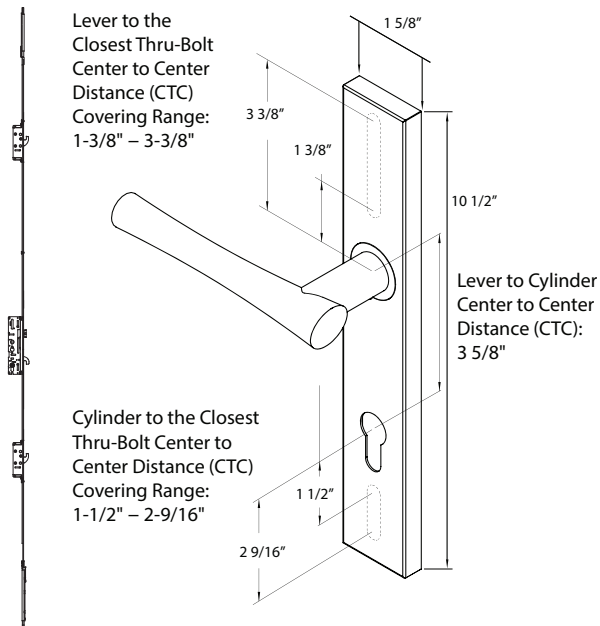

Twinpoint



Twinpoint Keyed

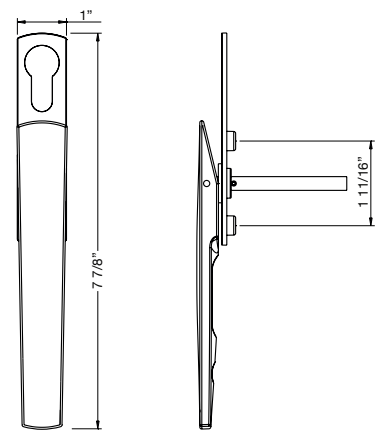

# G. WATER MANAGEMENT

Water management drawings below show impact rated folding sills, the same embed details apply for non-impact thermally broken folding sills.

## FULL EMBED

Standard Sill - Impact Rated

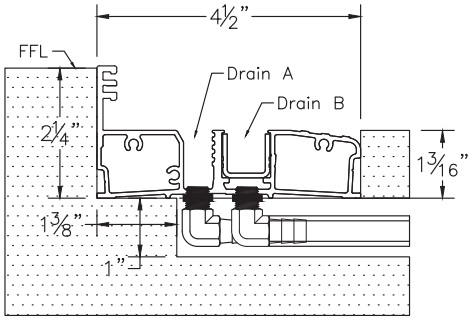

## HALF EMBED

Standard Sill - Impact Rated

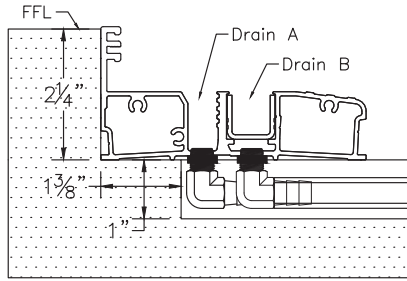

## NO EMBED

Standard Sill - Impact Rated

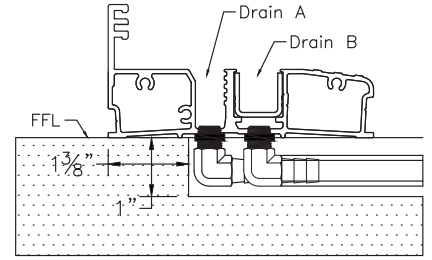

Modified Sill - Impact Rated

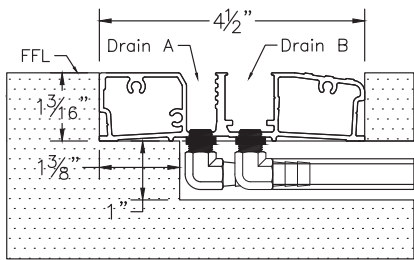

Modified Sill - Impact Rated

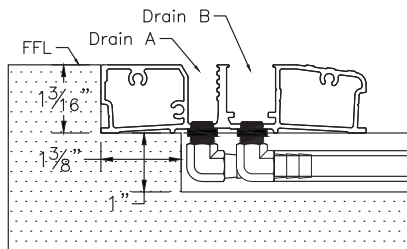

Modified Sill - Impact Rated

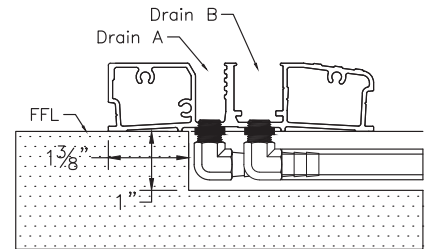

ADA Sill - Impact Rated

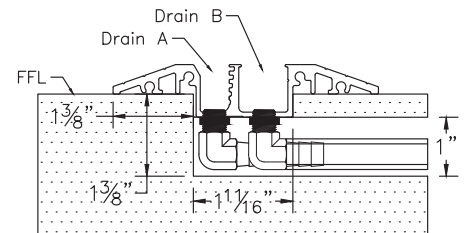

Channel Sill - Not Impact Rated

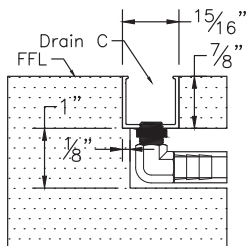

Channel Sill - Not Impact Rated

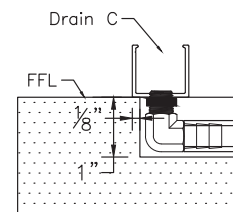

## H. KICKPLATE

---

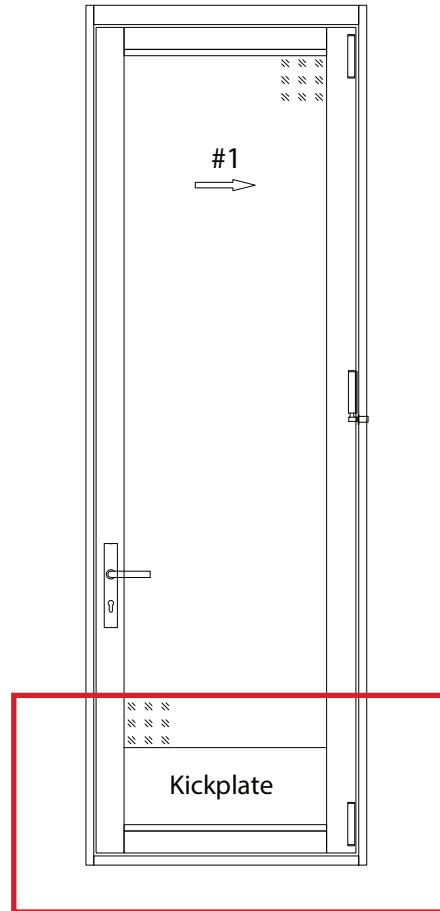

## I. LITES

---

A lite is a single pane of glass framed within a door. The below example of an 2L3R configuration showing each panel having 3 simulated divided lites wide and 9 simulated divided lites high.

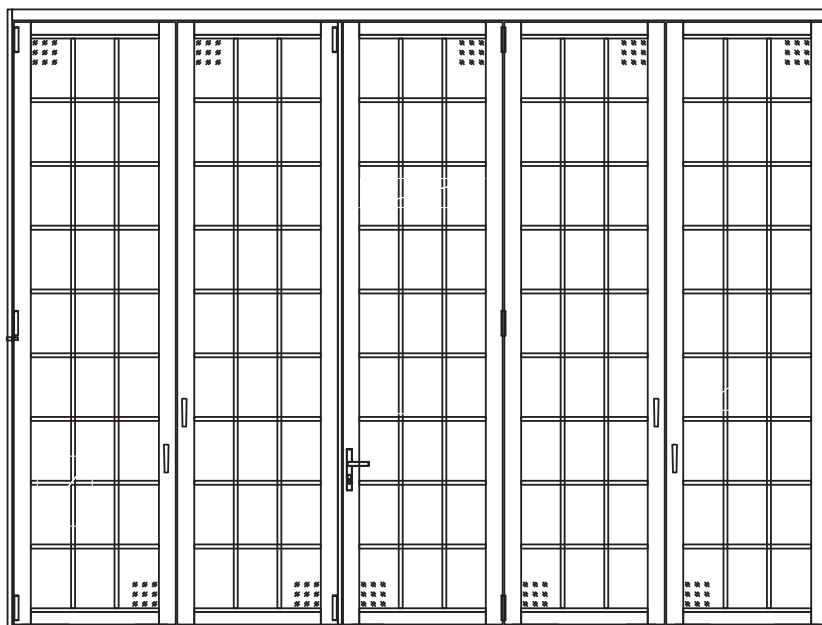

## J. MUNTIN

---

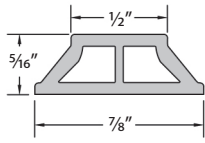

### 7/8" OGEE MUNTIN

Lift & Slide  
Folding / Stacking  
Pivot / Transom

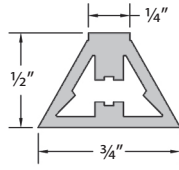

### 3/4" RAISED MUNTIN

Folding / Stacking  
Pivot / Transom

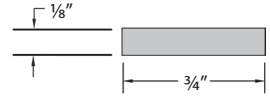

### 3/4" FLAT MUNTIN

Lift & Slide  
Multi Slide

## K. MULL BARS

---

Mull bars are used for joining up 2 or more doors in 1 opening.

